

INSTRUCTION MANUAL

McINTOSH MODEL MC-60

60 WATT POWER AMPLIFIER

Type A-121

Serial No. 5F846 and above

McINTOSH LABORATORY, INC.

2 Chambers St. Binghamton, N. Y.

U.S.A.

ELECTRICAL AND MECHANICAL SPECIFICATIONS

Specifications for the McIntosh Model MC-60 Audio Amplifier

Power Supply	117/125 volts, 50/60 cycles
Power Consumption	280 watts at 60 watts output 155 watts at zero signal output
Power Output	60 watts continuous
Input Level	Input #1, 0.5 volts to 30 volts, with gain control Input #2, 2.5 volts (for use with McIntosh Audio Compensators and Pre-Amps)
Frequency Range	20 to 30,000 cycles \pm .1 db at 60 watts output 16 to 60,000 cycles \pm .5 db at 60 watts output 10 to 100,000 cycles \pm 1.0 db at 30 watts output
Harmonic Distortion	Less than 0.5% at 60 watts output or less, 20 to 20,000 cycles.
Intermodulation Distortion	Less than 0.5% instantaneous peak power is below 120 watts
Impulse Distortion	Negligible
Noise and Hum Level	90 db or more below rated output
Damping Factor	12 or better for 4, 8, and 16 ohm output, 16 for 600 ohms
Input Impedance	0.5 meg for 0.5 volt input and 0.13 meg for 2.5 volt input, 20 cycles to 40 KC
Output Impedance	4, 8, 16, 83 (70.7 volts) and 600 ohms (600 ohm is balanced to ground)
Phase Shift	$\pm 8^\circ$ 20-20,000 cycles
Tube Complement	Rectifier: 2-5U4GB Pre-Amp: 12AX7 Phase Inverter: 12AU7 Voltage Amp: 12BH7 Driver: 12AX7 Output: 2KT-88/6550
Auxiliary Equipment Connection	Designed to power C-4, C-8 and other McIntosh pre-amplifiers
Size	14" x 10" x 8" high, chassis type construction
Weight	46 pounds net
Finish	Chrome and Black

DESCRIPTION

The McIntosh Model MC-60 is a 60 watt high fidelity power amplifier designed for home entertainment systems and professional applications where high power and distortion free performance is required. The Model MC-60, like all other McIntosh power amplifiers, uses the exclusive McIntosh high efficiency output circuit and bifilar output transformer to obtain the high standard of performance found in this amplifier. Some of the more important characteristics of the amplifier are; less than 0.5% harmonic distortion at any power output up to 60 watts and at any frequency in the audio spectrum, 20 to 20,000 cps; less than 0.5% inter-modulation distortion for all power levels up to 120 instantaneous peak watts; and noise and hum level 90 db or more below the rated output level.

The MC-60 has two high impedance inputs and may be operated from any signal source delivering 0.5 volts or more, or directly from a McIntosh Audio Compensator or Pre-Amplifier. Output impedance of 4, 8 and 16 ohms are provided for direct connection to loudspeakers. Additional outputs for 83 ohms (70.7 volts) and 600 ohms are provided for use with multiple speaker systems, lines, etc.

INSTALLATION

Location

The MC-60 should be located in a well-ventilated area. If the amplifier is housed in a cabinet or other enclosure, holes must be provided for air circulation.

Input Connections

1. When a McIntosh Audio Compensator or Pre-Amplifier of the non-self powered type is used with the MC-60, plug the pre-amplifier's output-power cord into the "PRE-AMP INPUT" receptacle on the MC-60 and turn the "GAIN" control fully counter clockwise. This receptacle supplies the required plate and filament power to the pre-amplifier equipment as well as providing the necessary audio connections.

For pre-amplifier installation, adjustment and operation refer to the pre-amplifier's instruction manual.

2. When using a self-powered McIntosh Audio Compensator or Pre-Amplifier, connect the audio output from the pre-amplifier to the input of the MC-60 using the cable supplied with the pre-amplifier. Turn the "GAIN" control fully counter clockwise.

3. When a signal source of 0.5 volts or more is used to drive the MC-60, such as the output of a tuner, tape recorder, or other pre-amplifiers, plug the source into the "0.5 VOLT" pin jack receptacle or connect to the "0.5 VOLT" and "GND" screw terminals. Use the "GAIN" control to obtain the desired operating level.

If desired, the signal source may be wired to an octal plug for insertion in the octal "Pre-Amp Input" receptacle. In this case connect the input lead to pin #5 and the ground lead to pin #1. When using this connection the source must not have a DC output component.

Output Connections

The MC-60 has output impedances of 4, 8 and 16 ohms available at either the screw terminal connector or the output socket. In addition, a 600 ohm output (balanced to ground) is available at the output socket. See schematic diagram for socket connections.

It is important that the loudspeaker or other load be properly matched to the amplifier if best performance is to be obtained. Because many loudspeakers do not have voice coil impedances exactly matching 4, 8 and 16 ohms, the following table lists suggested connections for the best impedance matching.

Speaker Impedance	3.2 to 6.5 ohms	6.5 to 13 ohms	13 to 32 ohms
Connect to	4 ohms	8 ohms	16 ohms

WARNING: Output plugs wired for McIntosh 20W-2 and 50W-2 amplifiers must not be used with the MC-60 without rewiring the plug.

Output connections for the MC-30 are the same as those for the MC-60.

Power Connections

The MC-60 operates from any 110 to 130 volt 50-60 cycles power line. (When continuous use is contemplated on 120 to 130 line volts the transformer primary should be re-connected using the 125 volt tap.)

When the MC-60 is used with McIntosh Pre-Amplifier equipment, tuners, or other associated equipment, the MC-60 power cord may be plugged into the receptacle at the rear of these units. When thus connected the power switch of these units controls the MC-60.

GUARANTEE

We guarantee the performance of this equipment and the mechanical and electrical workmanship to be free of defects for a period of 90 days. This guarantee does not extend to components damaged by improper use nor does it extend to transportation to and from the factory.

SERVICE INFORMATION

All McIntosh equipment is designed for long trouble free operation. All components are of the highest quality and are conservatively operated. If trouble develops the amplifier may be serviced by your franchised dealer, a competent serviceman, or returned to the factory. Equipment will not be accepted at the factory unless factory return authorization is first received. The following chart of operating voltages and resistances is offered as a guide for servicing the unit. All voltages and resistances are measured to chassis except those with asterick (*). These are measured to chassis with pin #2 of either 5U4GB grounded. Voltages are measured with high impedance VTVM NOTE - UNIT MUST BE TURNED OFF WHEN MEASURING RESISTANCES.

VOLTAGE AND RESISTANCE CHART					
Tube	Pin No.	DC Volts	DC Volts	AC Volts	Resistance Unit Off
		No Signal	at 60W out	at 60W out	
12AX7 (Input)	1	134	120	1.5	330K*
	2	0	0	.4	1M
	3	1.2	1.1	.4	3.3K
	4 & 5	Fil	6.3 V. ac to pin 9	-	0 to 70
	6, 7, 8	-	-	-	-
	9	Fil	-	-	0 to 70
12AU7	1	270	235	11	40*
	2	134	120	1.5	330K*
	3 & 4	138	126	0.6	18K
	4 & 5	Fil	6.3 V ac to Pin 9	-	0 to 70
	6	270	235	11	43K*
	7	110	100	0	2.6M*
12BH7	9	Fil	-	-	0 to 70
	1	340	290	148	12K*
	2	0	0	11	200K
	3 & 8	16	14	0.32	1.2K
	4 & 5	Fil	6.3V ac to Pin 9	-	0 to 70
	6	340	290	148	12K*
	7	0	0	11	200K
	9	Fil	-	-	0 to 70

Tube	Pin No.	DC Volts No Signal	DC Volts at 60W out	AC Volts at 60W out	Resistance Unit Off
12AX7	1	435	365	106	45*
	2	-46	-46	148	1M
	3	-45	-45	148	270K
	4 & 5	Fil	6.3V ac to Pin 9	-	0 to 70
	6	435	36S	106	45*
	7	-46	.46	148	1M
	8	-45	-45	148	270K
	9	Fil	-	-	0 to 70
	KT-88/6550 (Both tube*)	1	0	0	0
2		Fil	6.3V.ac to Pin 7	-	0 to 70
3		435	365	106	45*
4		435	365	110	45*
5		-45	-45	148	270K
6		-	-	-	-
7		Fil	-	-	0 to 70
8		.8	2.5	110	12
5U4GB (Both tubes)	1	-	-	-	-
	2	440	380	8.9(ripple)	0*
	3	-	-	-	-
	4	375AC	370AC	370	15
	5	-	-	-	-
	6	375AC	370AC	370	15
	7	-	-	-	-
	8	440	380	-	0*

Pins not listed are either filaments, have no voltage or are not used.

U. S. Patents No. 2, 477, 074; 2, 545, 788; 2, 646, 467; 2, 654, 058 others pending.

McINTOSH LABORATORY, INC.

2 Chambers Street

Binghamton, N. Y., U.S.A.

In Canada: Manufactured Under License by McCurdy Radio Industries, Ltd.
22 Front Street West, Toronto, Canada

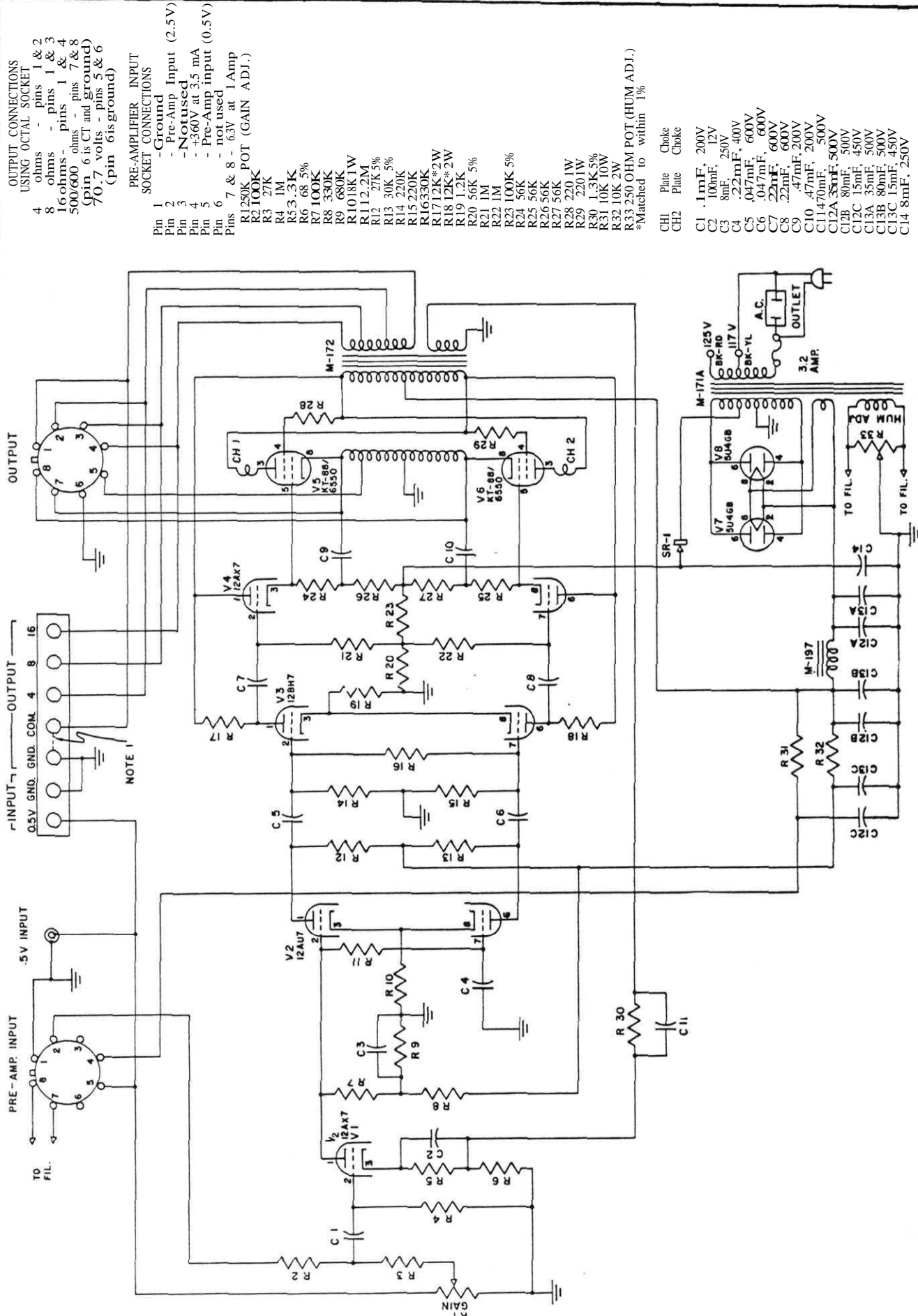

OUTPUT CONNECTIONS
USING OCTAL SOCKET

4 ohms - pins 1 & 2
8 ohms - pins 1 & 3
16 ohms - pins 1 & 4
500/600 ohms - pins 7 & 8
(pin 6 is CT and ground)
70.7 volts - pins 5 & 6
(pin 6 is ground)

PRE-AMPLIFIER INPUT
SOCKET CONNECTIONS

Pin 1 - Ground
Pin 2 - Pre-Amp Input (2.5V)
Pin 3 - Not used
Pin 4 - +360V at 3.5 mA
Pin 5 - Pre-Amp input (0.5V)
Pin 6 - not used
Pins 7 & 8 - 6.3V at 1 Amp

R1 250K POT (GAIN ADJ.)
R2 100K
R3 27K
R4 1M
R5 3.3K
R6 .68 5%
R7 100K
R8 330K
R9 680K
R10 18K
R11 2.2M
R12 27K 5%
R13 30K 5%
R14 220K
R15 220K
R16 330K
R17 12K*2W
R18 12K*2W
R19 1.2K
R20 56K 5%
R21 1M
R22 1M
R23 100K 5%
R24 56K
R25 56K
R26 56K
R27 56K
R28 220 1W
R29 220 1W
R30 1.5K 5%
R31 10K 10W
R32 10K 2W
R33 250 OHM POT (HUM ADJ.)
*Matched to within 1%

CH1 Plate
CH2 Plate

Choke
Choke

C1 .1mF, 200V
C2 .10mF, 12V
C3 8mF, 250V
C4 .22mF, 400V
C5 .047mF, 600V
C6 .047mF, 600V
C7 .22mF, 600V
C8 .22mF, 600V
C9 .47mF, 200V
C10 .47mF, 200V
C11 470mF, 500V
C12A 35mF, 500V
C12B 80mF, 500V
C12C 15mF, 450V
C13A 35mF, 500V
C13B 80mF, 500V
C13C 15mF, 450V
C14 8mF, 250V

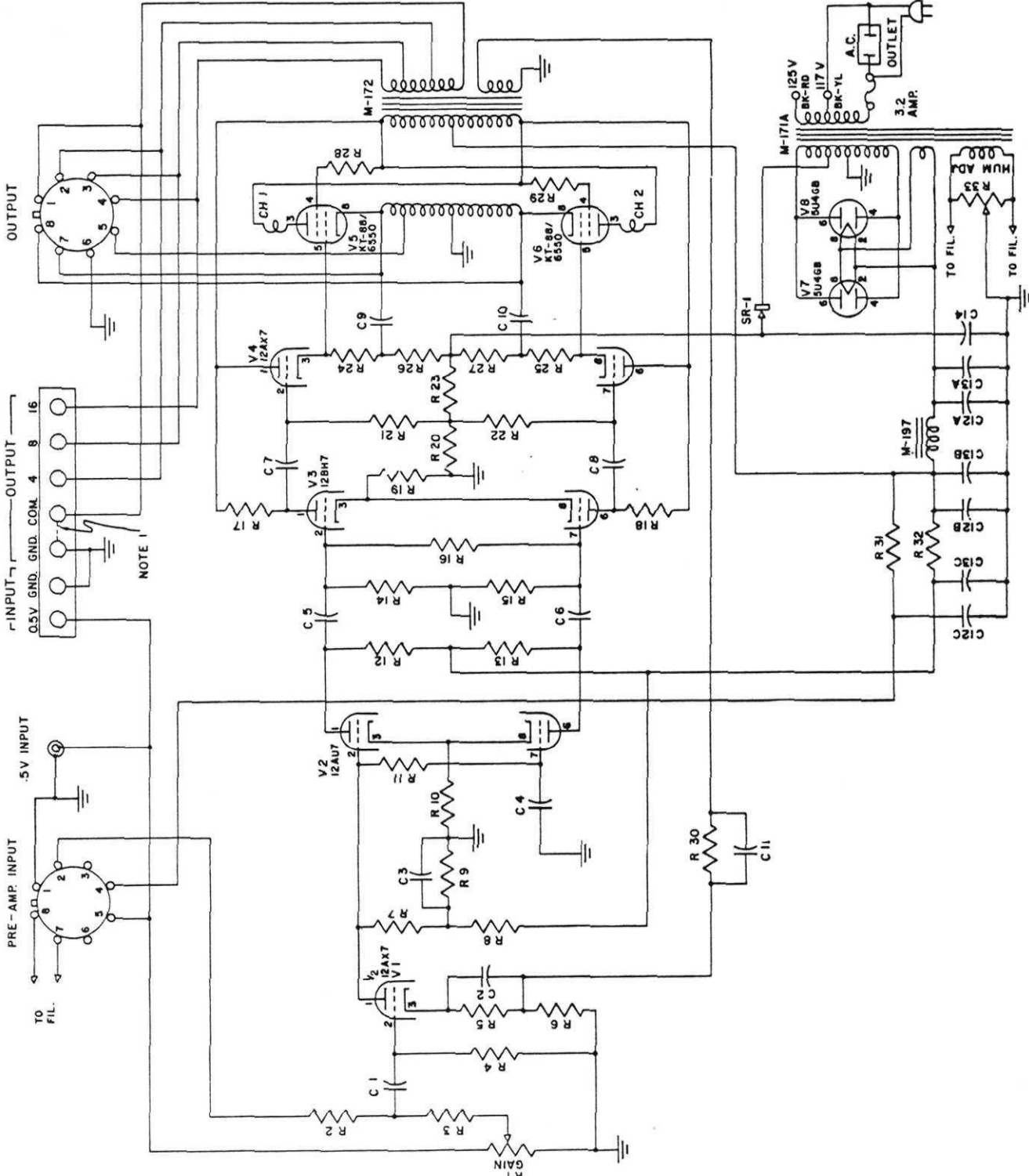

OUTPUT

PRE-AMPLIFIER INPUT

CH 1

CH 2

3.2 AMP

TO FIL.

REVISIONS		SCALE		MATERIAL	
NO.	DATE	BY	SCALE	DATE	SCHEMATIC NO.
1				4-18-60	SC 14-127
2					
3					
4					
5					

MCINTOSH LABORATORY, INC.
2 CHAMBERS ST. BINGHAMTON, N. Y.

MODEL MC-80, TYPE A-125 POWER AMPLIFIER

DATE BY V.G. SCALE DATE 4-18-60 MATERIAL
CMT'S JAL. DATE 4-18-60 SCHEMATIC NO. SC 14-127
PAGE 3 OF 3

NOTE 1 - THIS JUMPER STRAP MAY BE REMOVED IF UNGROUNDED LOW IMPEDANCE OUTPUTS ARE DESIRED

SERIAL NO 3FB46 AND ABOVE

